

AQUATIO

bios antibacterial washbasins and shower trays



CASALGRANDE
PADANA
THE GREEN WAY TO PAVE

IN COPERTINA
ON THE COVER
EN COUVERTURE
AUF DER TITELSEITE

WALL:

Marmoker_Calacatta Extra Lucido

WASHBASIN:

Clear.90_Marmoker_Calacatta Extra Honed

AQUATIO

4 Intro

12 Collection

Washbasins

Clear

Clear/double

Limpid

Fluid

Shelves

Cool

Pure

Shower trays

Clean

Fresh

36 Tech Info



WALL: Supreme_Dark Naturale 120x278 cm
FLOOR: Supreme_Sand Naturale 120x120 cm
AQUATIO: Clear.120_Supreme_Sand Naturale



Casalgrande Padana firma l'unica linea di complementi d'arredo per lo spazio bagno composta da lavabi, mensole e piatti doccia in gres porcellanato **antibatterico**, perfettamente abbinabili con le superfici ceramiche presenti a catalogo, per soluzioni total look coordinate a pavimenti e rivestimenti, o applicazioni ricercate che giocano su contrasti inediti tra materiali, forme e colori.

EN Casalgrande Padana is proud to present the only range of porcelain stoneware washbasins, shower trays, and shelves with **antibacterial properties** for classy bathrooms. These furnishings perfectly match the tile collections in the catalogue, allowing you to create a seamless, cohesive look or sophisticated combinations of contrasting shapes, colours, and materials.

FR Casalgrande Padana signe la seule ligne de compléments d'ameublement destinée à la salle de bains composée de vasques, de tablettes et de receveurs de douche en grès cérame **antibactérien**. Pouvant être parfaitement associée aux surfaces céramiques présentes dans le catalogue, cette ligne permet de créer des solutions total look coordonnées avec le sol et les murs, ou des applications élégantes qui jouent sur les contrastes inédits entre les matériaux, les formes et les couleurs.

DE Casalgrande Padana hat eine einzigartige Produktlinie für die Einrichtung von Badezimmern entworfen, bestehend aus Waschbecken, Ablagen und Duschtassen aus **antibakteriellem** Feinsteinzeug, die sich perfekt mit den Keramikoberflächen des Katalogs kombinieren lassen, um Gesamtlösungen zu schaffen, die auf Bodenbeläge und Wandverkleidungen abgestimmt sind, oder für elegante Anwendungen, die mit ungewöhnlichen Kontrasten zwischen Materialien, Formen und Farbgebungen spielen.



WALL: Supreme_Dark Naturale 120x278 cm
FLOOR: Supreme_Sand Naturale 120x120 cm
AQUATIO: Clear.120_Supreme_Sand Naturale

La linea Aquatio valorizza le superiori qualità del gres porcellanato di Casalgrande Padana in termini di durezza, resistenza e facilità di pulizia, che vengono ulteriormente potenziate grazie a **bios antibacterial**[®], l'esclusivo trattamento a base di argento in grado di eliminare al 99% i batteri presenti sulla superficie ceramica per garantire la massima igienicità, assicurando elevate performance tecniche ed estetiche.

EN The Aquatio range stands out for its beauty and superior durability, wear resistance, and ease of cleaning, typical of Casalgrande Padana porcelain stoneware. These technical features are further enhanced by **bios antibacterial**, the exclusive silver-based treatment that helps eliminate 99% of bacteria from the tiles' surfaces, ensuring impeccable hygiene.

FR La ligne Aquatio met en valeur les qualités supérieures du grès cérame de Casalgrande Padana en ce qui concerne la longévité, la résistance et la facilité de nettoyage. Ces atouts sont renforcés grâce à **bios antibacterial**, le traitement exclusif à base d'argent en mesure d'éliminer à 99 % les bactéries présentes sur la surface céramique afin d'assurer une hygiène maximale tout en offrant d'excellentes performances techniques et esthétiques.

DE Die Produktlinie Aquatio unterstreicht die überlegenen Qualitätsmerkmale des Feinsteinzeugs von Casalgrande Padana in Bezug auf Langlebigkeit, Widerstandsfähigkeit und Reinigungsfreundlichkeit, die durch **bios antibacterial** die exklusive Behandlung auf Silberbasis, die 99 % der auf der Keramikoberfläche vorhandenen Bakterien eliminiert, noch zusätzlich verstärkt werden, um ein Höchstmaß an Hygiene zu garantieren und eine hohe technische und ästhetische Qualität zu gewährleisten.



WALL: Supreme_Dark Naturale 120x278 cm
FLOOR: Supreme_Sand Naturale 120x120 cm
AQUATIO: Fresh.120_Supreme_Sand Naturale

Le prestazioni impareggiabili di bios antibacterial®

The unrivalled performance of bios antibacterial®
Les performances incomparables de bios antibacterial®
Die unübertroffene Leistungsfähigkeit von bios antibacterial®



Battericida Uccide i batteri al 99%

Bios Antibacterial® adotta una tecnologia agli ioni d'argento che blocca il metabolismo dei batteri, eliminandoli e impedendone la proliferazione, con un'efficacia testata sui quattro principali ceppi batterici.

Bactericidal Kills 99% of bacteria

Bios Antibacterial® uses a silver ion technology that blocks the metabolism of bacteria, eliminating them and preventing them from spreading, with efficacy tested on the four main strains of bacteria.

Bactéricide

Élimine les bactéries à 99 % Bios Antibacterial® adopte une technologie aux ions d'argent qui inhibe le métabolisme des bactéries, en les éliminant et en empêchant leur prolifération. Son efficacité est testée sur les quatre principales souches bactériennes.

Bakterizid

Tötet 99 % der Bakterien ab Bios Antibacterial® basiert auf der Silberionentechnologie, die den Stoffwechsel von Bakterien blockiert, sie eliminiert und ihre Vermehrung verhindert, wobei die Wirksamkeit bei den vier wichtigsten Bakterienstämmen nachgewiesen ist.



Sempre attivo Protezione continua h 24

Lo scudo protettivo di Bios Antibacterial® è sempre attivo, giorno e notte, con o senza luce solare, e non necessita di raggi UV per l'attivazione.

Always active Protection 24/7

The protective shield formed by Bios Antibacterial® is always active, day and night, with or without sunlight, and does not require UV rays for activation.

Toujours actif Protection permanente 24h/24

Le bouclier protecteur de Bios Antibacterial® est toujours actif, jour et nuit, avec ou sans rayonnement solaire, et, pour son activation, les rayons UV ne sont pas nécessaires.

Immer aktiv Dauerhafter 24-Stunden-Schutz

Der Schutzschild von BIOS Antibacterial® ist immer aktiv, Tag und Nacht, mit oder ohne Sonnenlicht, und benötigt keine UV-Strahlen zur Aktivierung.



Anti-odore Elimina i cattivi odori

Oltre al potere battericida, Bios Antibacterial® evita la formazione di muffe, lieviti e funghi, principali responsabili dei cattivi odori, rendendo gli ambienti più sani e gradevoli all'olfatto.

Anti-odour Eliminates unpleasant odours

In addition to its bactericidal capacity, Bios Antibacterial® prevents the formation of mould, yeast and fungi, the main culprits of unpleasant odours, thus making settings healthier and with a more pleasant smell.

Anti-odeurs Élimine les mauvaises odeurs

En plus de son pouvoir bactéricide, Bios Antibacterial® évite l'apparition de moisissures, de levures et de champignons, principaux responsables des mauvaises odeurs, ce qui permet de rendre les espaces plus sains et plus agréables à l'odorat.

Geruchshemmend Beseitigt unangenehme Gerüche

Zusätzlich zu seiner bakteriziden Wirkung verhindert Bios Antibacterial® die Bildung von Schimmel, Hefen und Pilzen, den Hauptverursachern schlechter Gerüche, und macht die Umgebung gesünder und angenehmer im Geruch.



Facile da pulire Elevate prestazioni igieniche

Grazie alla loro impermeabilità naturale e all'assenza di porosità, le superfici ceramiche vantano una velocità e facilità di pulizia superiore rispetto ad altri materiali.

Easy to clean Excellent hygiene performance

Because they are naturally impermeable and non-porous, ceramic surfaces are quicker and easier to clean than other materials.

Facile à nettoyer Performances élevées en termes d'hygiène

Grâce à leur imperméabilité naturelle et à l'absence de porosité, les surfaces céramiques sont plus faciles et plus rapides à nettoyer que les autres matériaux.

Leicht zu reinigen Hervorragende hygienische Eigenschaften

Dank ihrer natürlichen Undurchlässigkeit und Porenfreiheit lassen sich Keramikoberflächen schneller und einfacher reinigen als andere Materialien.

IT Essendo il trattamento antibatterico integrato in maniera permanente nel prodotto ceramico, le sue proprietà sono sempre attive, sia con luce che al buio e, al contrario di molti prodotti presenti sul mercato definiti antibatterici, non ha bisogno di raggi UV per l'attivazione. La commercializzazione di Bios Antibacterial® è autorizzata e approvata dal Regolamento Europeo sui Biocidi (EU BPR 528/2012).

EN The antibacterial treatment is incorporated permanently into the tiles and is always active, day and night, without needing UV radiation like similar products marketed as antibacterial. Bios Antibacterial® complies with the Biocidal Products Regulation (BPR, Regulation (EU) 528/2012).

FR Le traitement antibactérien étant intégré de façon permanente dans le produit céramique, ses propriétés sont toujours actives, de jour comme de nuit, et, contrairement à de nombreux produits présents sur le marché définis comme antibactériens, les rayons UV ne sont pas nécessaires à son activation. La commercialisation de Bios Antibacterial® est autorisée et approuvée par le Règlement européen sur les produits biocides (UE BPR 528/2012).

DE Da die antibakterielle Behandlung dauerhaft in das keramische Produkt integriert ist, ist ihre Wirkung sowohl bei Licht als auch bei Dunkelheit immer aktiv, und im Gegensatz zu vielen als antibakteriell deklarierten Produkten auf dem Markt benötigt sie kein UV-Licht zur Aktivierung. Die Vermarktung von Bios Antibacterial® ist durch die europäische Biozid-Verordnung (EU BPR 528/2012) zugelassen und genehmigt.

bios
antibacterial®

A partire da grandi lastre in gres porcellanato, Casalgrande Padana crea una serie di modelli standard per lavabi, mensole e piatti doccia, anche personalizzabili nelle dimensioni secondo le esigenze specifiche di designer e architetti, per rendere ogni scelta progettuale completamente custom-made.

EN Casalgrande Padana's range of porcelain stoneware washbasins, shelves, and shower trays can be customised in size to meet designers' and architects' needs and allow for tailor-made solutions.

FR Casalgrande Padana crée une série de modèles standard de vasques, de tablettes et de receveurs de douche réalisés à partir de grandes dalles en grès cérame. Les dimensions peuvent également être personnalisées en fonction des exigences spécifiques des designers et des architectes pour une conception entièrement sur mesure.

DE Ausgehend von großformatigen Feinsteinzeugplatten entwickelt Casalgrande Padana eine Reihe von Standardmodellen für Waschbecken, Ablagen und Duschtassen, die in ihren Abmessungen an die spezifischen Anforderungen von Designern und Architekten ebenfalls angepasst werden können, damit jede Gestaltungsentscheidung vollkommen nach Maß getroffen werden kann.

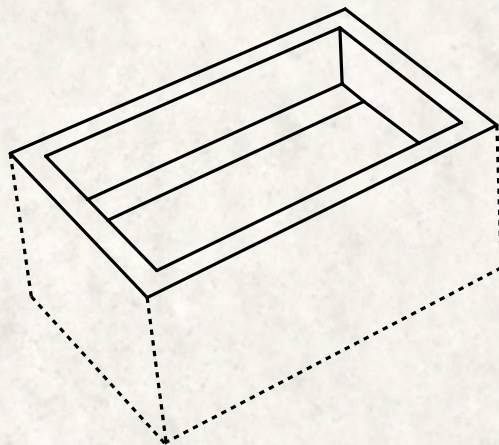
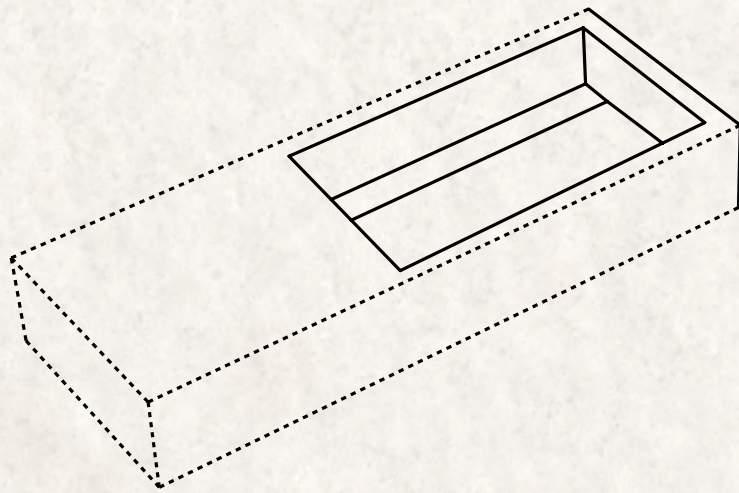
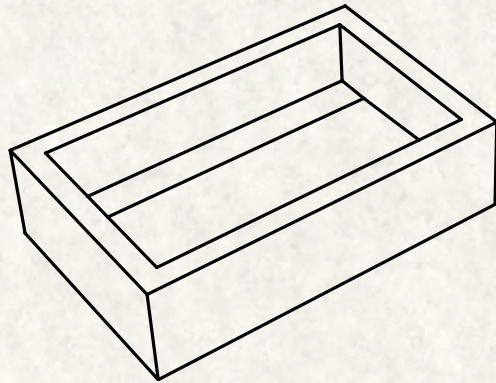

AQUATIO

AQUATIO

Una narrazione intorno all'acqua affiora in superficie
per dare il nome alla nuova linea di complementi d'arredo
di Casalgrande Padana.

A new idea emerges from water
giving its name to Casalgrande Padana's
new range of bathroom furnishings.

Un récit sur l'eau fait surface
et donne son nom à la nouvelle ligne
de compléments d'ameublement de Casalgrande Padana.

Eine Erzählung zum Thema Wasser erhebt sich an die Oberfläche
und gibt der neuen Produktlinie für Einrichtungselemente
von Casalgrande Padana ihren Namen.

AQUATIO

SPECIES

Lavabi
Washbasins

Fluid.50



LAVABO FREESTANDING
FREESTANDING WASHBASIN

Clear.90



LAVABO INTEGRATO
BUILT-IN WASHBASIN

Clear.120



LAVABO INTEGRATO
BUILT-IN WASHBASIN

Clear/double.180



DOPPIO LAVABO INTEGRATO
BUILT-IN DOUBLE WASHBASIN

Limpid.50



LAVABO IN APPOGGIO
COUNTERTOP WASHBASIN

Limpid.90





LAVABO IN APPOGGIO
COUNTERTOP WASHBASIN

Limpid.120



LAVABO IN APPOGGIO
COUNTERTOP WASHBASIN

AQUATIO

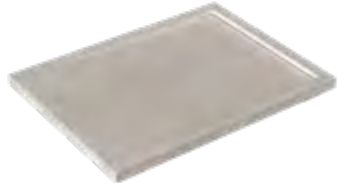
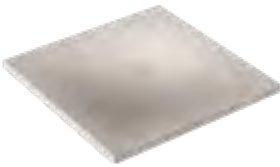
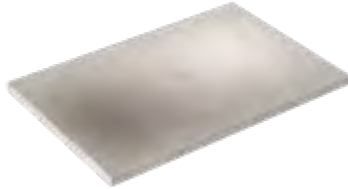
<p>Mensole Shelves</p>	<p>Cool.60/75/90</p>  <p>PIANO PORTA OGGETTI BATHROOM SHELF</p>	<p>Pure.90/120/180</p>  <p>PIANO LAVABO VANITY TOP</p>
<p>Piatti doccia Shower trays</p>	<p>Clean.80/90</p>  <p>PIATTO DOCCIA CON CANALINA SHOWER TRAY WITH CHANNEL DRAIN</p>	<p>Clean.120</p>  <p>PIATTO DOCCIA CON CANALINA SHOWER TRAY WITH CHANNEL DRAIN</p>
<p>Fresh.80/90</p>  <p>PIATTO DOCCIA TERMOFORMATO THERMOFORMED SHOWER TRAY</p>	<p>Fresh.120</p>  <p>PIATTO DOCCIA TERMOFORMATO THERMOFORMED SHOWER TRAY</p>	<p>Tech info pag.48</p> <p>DIMENSIONI E CARATTERISTICHE SIZES AND FEATURES</p>



WALL: Marmoker_Statuario Grigio Lucida 120x278 cm
FLOOR: Marmoker_Statuario Grigio Lucida 120x120 cm
AQUATIO: Clear/double.180_Pure.180_Cool.60_Marmoker_Ossidiana Lucida

AQUATIO



Pure.180

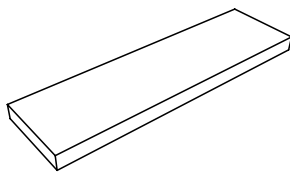

● Ossidiana Lucida
MARMOKER

Clear/double.180

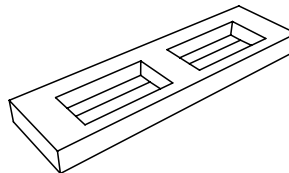

● Ossidiana Lucida
MARMOKER

Cool.60

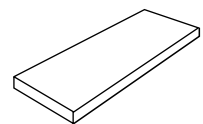

○ Statuario Grigio Lucida
MARMOKER

AQUATIO



AQUATIO



WALL: **Marmoker_Statuario Grigio** Lucida 120x278 cm
FLOOR: **Marmoker_Statuario Grigio** Lucida 120x120 cm
AQUATIO: **Clear/double.180_Marmoker_Ossidiana** Lucida



WALL: **Metropolis_Sand** Naturale 120x278 cm
FLOOR: **Metropolis_Sand** Naturale 60x120 cm
AQUATIO: **Limpid.90_Pure.180/180T_Metropolis_Sand** Naturale

AQUATIO





WALL: **Metropolis_Sand Naturale** 120x278 cm
 FLOOR: **Metropolis_Sand Naturale** 60x120 cm
 AQUATIO: **Limpid.90_Pure.180/180T_Metropolis_Sand Naturale**

Limpid.90

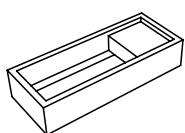

● **Sand Naturale**
METROPOLIS

Pure.180/180T

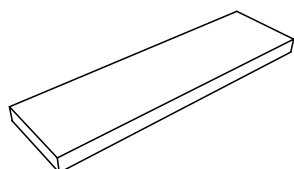

● **Sand Naturale**
METROPOLIS

AQUATIO



AQUATIO

WALL: **Metropolis_Sand** Naturale 120x278 cm
FLOOR: **Metropolis_Sand** Naturale 60x120 cm
AQUATIO: **Clean.120_Metropolis_Sand** Naturale



Clean.120

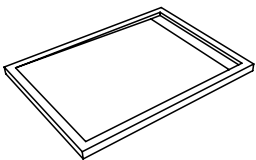

 **Sand Naturale**
METROPOLIS





WALL: **Marmoker_Grafite** Lucida 120x278 cm
FLOOR: **English Wood_Galloway** Naturale 20x120 cm
AQUATIO: **Fluid.50_Pure.120/Cool.60_Clean.90_Marmoker_Grafite** Lucida

AQUATIO



Fluid.50

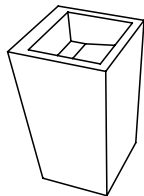

● Grafite Lucida
MARMOKER

Pure.120/Cool.60

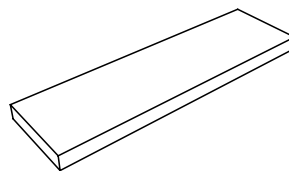

● Grafite Lucida
MARMOKER

Clean.90

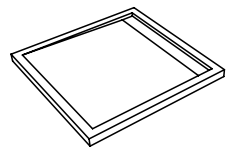

● Grafite Lucida
MARMOKER

AQUATIO



Limpid.50

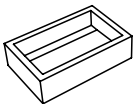

● Caprera Naturale
PIETRE DI SARDEGNA

Pure.120

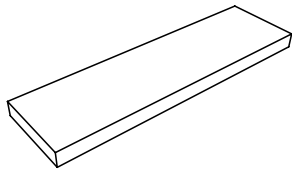

● Night Storm Lucida
MARMOKER



WALL: Marmoker_Night Storm Lucida 120x278 cm
FLOOR: Pietre di Sardegna_Capreria Naturale 120x120 cm
AQUATIO: Limpid.50_Pietre di Sardegna_Capreria Naturale
Pure.120_Marmoker_Night Storm Lucida



WALL: Pietre di Sardegna_Porto Rotondo Naturale 120x278 cm
FLOOR: Pietre di Sardegna_Porto Rotondo Naturale 60x120 cm
AQUATIO: Limpid.120_Pure.180_Fresh.90_Pietre di Sardegna_Porto Rotondo Naturale

AQUATIO



Limpid.120

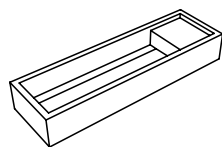

Porto Rotondo Naturale
PIETRE DI SARDEGNA

Pure.180

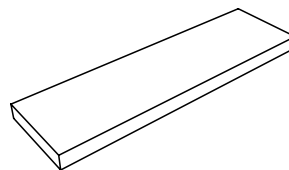

Porto Rotondo Naturale
PIETRE DI SARDEGNA

Fresh.90

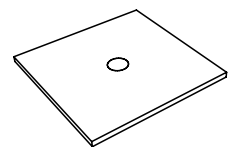

Porto Rotondo Naturale
PIETRE DI SARDEGNA

AQUATIO

WALL: **Stile_White Smoke** Naturale 60x120 cm_ **Nuances_Mercurio** Lux 8,2x25 cm
FLOOR: **Stile_White Smoke** Naturale 60x120 cm
AQUATIO: **Clear.90_Pure.180_Atelier_Indaco** Naturale



Clear.90

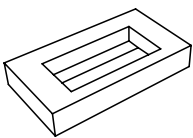

● **Indaco** Naturale
ATELIER

Pure.180

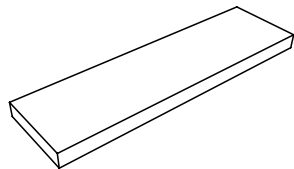

● **Indaco** Naturale
ATELIER



COLOURS



Titan White
MARMOKER



Calacatta Extra
MARMOKER



Statuario Grigio
MARMOKER

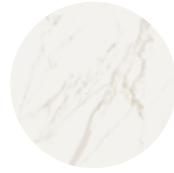

Statuario Oro
MARMOKER



Bianco Vietnam
MARMOKER



Bardiglio Bianco
MARMOKER

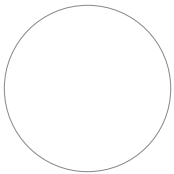

Canova
MARMOKER



Bardiglio Imperiale
MARMOKER



Grafite
MARMOKER

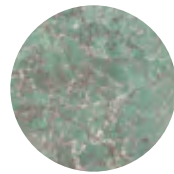

Carribbean Green
MARMOKER

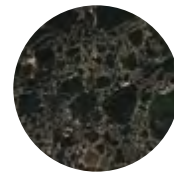

Orange Black
MARMOKER



Night Storm
MARMOKER

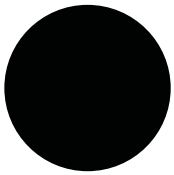

Ossidiana
MARMOKER



Marquinia Smart
MARMOKER



Tortora Smart
MARMOKER

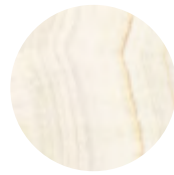

Onice Bianco
ONICI



Onice Ghiaccio
ONICI



Gré Bianco
PIETRE DI PARAGONE

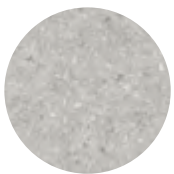

Gré Grigio
PIETRE DI PARAGONE

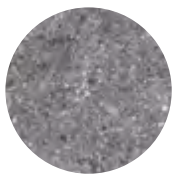

Gré Nero
PIETRE DI PARAGONE



Punta Molara
PIETRE DI SARDEGNA



Caprera
PIETRE DI SARDEGNA



Porto Rotondo
PIETRE DI SARDEGNA



Porto Cervo
PIETRE DI SARDEGNA



Cala Luna
PIETRE DI SARDEGNA



Tavolara
PIETRE DI SARDEGNA



Grey
SUPREME



Dark
SUPREME



Sand
SUPREME



Taupe
SUPREME

Su richiesta sono disponibili altri colori. Per una migliore visione di cromie e texture consultare i singoli cataloghi di collezione.
Other colours are available upon request. View each collection's catalogue for a better idea of colours and textures.

AQUATIO



Aventino Cross
PIETRA TIBURTINA



Aventino Vein
PIETRA TIBURTINA



Palatino Cross
PIETRA TIBURTINA



Palatino Vein
PIETRA TIBURTINA

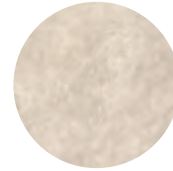

Campidoglio Cross
PIETRA TIBURTINA



Campidoglio Vein
PIETRA TIBURTINA



Celio Cross
PIETRA TIBURTINA



Celio Vein
PIETRA TIBURTINA



White
METROPOLIS



Almond
METROPOLIS



Silver
METROPOLIS



Sand
METROPOLIS



Grey
METROPOLIS



Mud
METROPOLIS



Greige
METROPOLIS

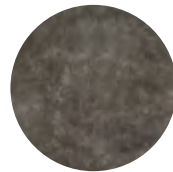

Grafite
METROPOLIS



White
FUSION



Grey
FUSION



Green
FUSION



Copper
FUSION



Graphite
FUSION

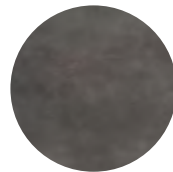

Black
FUSION

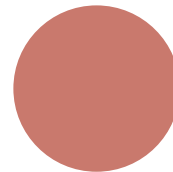

Rubino
ATELIER



Ottanio
ATELIER



Fiordaliso
ATELIER

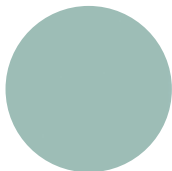

Lavanda
ATELIER

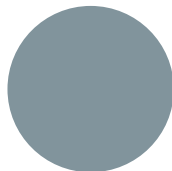

Indaco
ATELIER

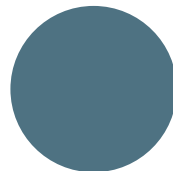

Oltremare
ATELIER

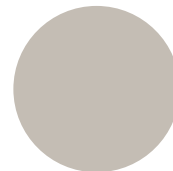

Brume
ATELIER



Cristallo
ATELIER

D'autres couleurs sont disponibles sur demande. Pour un meilleur aperçu des couleurs et des textures, veuillez consulter les catalogues des différentes collections.
Weitere Farbgebungen sind auf Anfrage erhältlich. Eine bessere Übersicht über Farbgebungen und Texturen finden Sie in den jeweiligen Kollektionskatalogen.

Tech Info

Clear

Lavabi
Washbasins

LAVABO INTEGRATO CON CANALINA D'ISPEZIONE

BUILT-IN WASHBASIN
WITH A CHANNEL DRAIN

VASQUE INTÉGRÉE
AVEC GOULOTTE D'INSPECTION

INTEGRIERTES WASCHBECKEN
MIT INSPEKTIONSRINNE

Clear.90

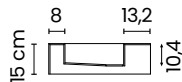
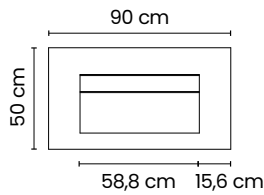
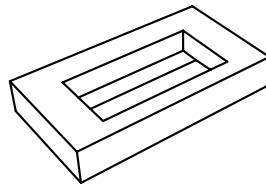

Clear.120

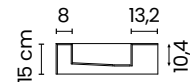
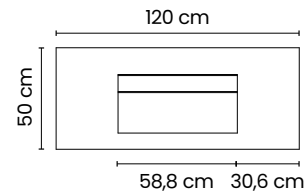
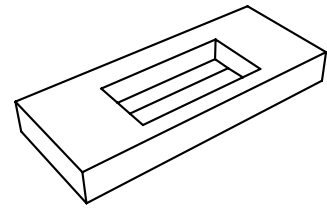

Possibilità di fissaggio a muro o in appoggio su apposita mensola. Ogni lavabo è fornito in apposita cassa Fao. Staffe di supporto su richiesta.
| Can be wall-mounted or mounted on a vanity shelf. Each washbasin comes in an ISPM 15 certified crate. Support brackets are available upon request. | Possibilité de la fixer au mur ou de la poser sur une tablette prévue à cet effet. Chaque vasque est emballée dans une caisse spéciale Fao. Supports de fixation sur demande. | Für die Montage an der Wand oder auf einer entsprechenden Auflageplatte. Jedes Waschbecken wird in einer entsprechenden Fao-Kiste geliefert. Halterungen auf Anfrage.

Clear

Lavabi
Washbasins

DOPPIO LAVABO INTEGRATO CON CANALINA D'ISPEZIONE

BUILT-IN DOUBLE WASHBASIN
WITH A CHANNEL DRAIN

DOUBLE VASQUE INTÉGRÉE
AVEC GOULOTTE D'INSPECTION

INTEGRIERTES DOPPELWASCHBECKEN
MIT INSPEKTIONSRINNE

Clear/double.180

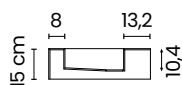
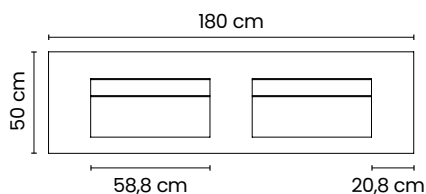
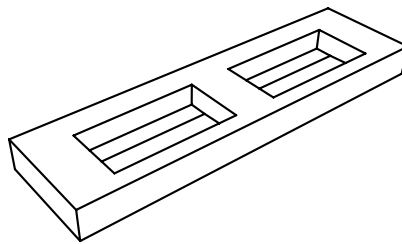

Possibilità di fissaggio a muro o in appoggio su apposita mensola. Ogni lavabo è fornito in apposita cassa Fao. Staffe di supporto su richiesta.
| Can be wall-mounted or mounted on a vanity shelf. Each washbasin comes in an ISPM 15 certified crate. Support brackets are available upon request. | Possibilité de la fixer au mur ou de la poser sur une tablette prévue à cet effet. Chaque vasque est emballée dans une caisse spéciale Fao. Supports de fixation sur demande. | Für die Montage an der Wand oder auf einer entsprechenden Auflageplatte. Jedes Waschbecken wird in einer entsprechenden Fao-Kiste geliefert. Halterungen auf Anfrage.

Clear T

Lavabi
Washbasins

**LAVABO INTEGRATO
CON CANALINA D'ISPEZIONE
E FORO PER RUBINETTERIA**

BUILT-IN WASHBASIN
WITH A CHANNEL DRAIN
AND A TAP HOLE

VASQUE INTÉGRÉE
AVEC GOULOTTE D'INSPECTION
ET TROU POUR ROBINETTERIE
INTEGRIERTES WASHBECKEN
MIT INSPEKTIONSRIINNE UND
ARMATURENBOHRUNG

Clear.90 T

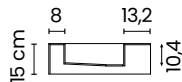
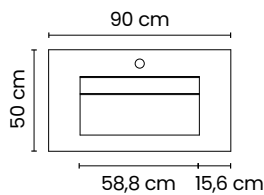
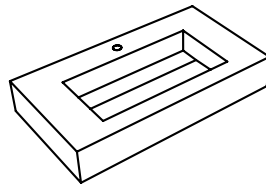

Clear.120 T

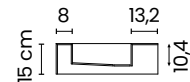
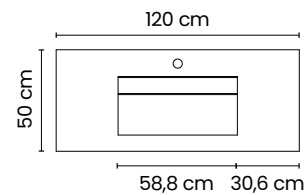
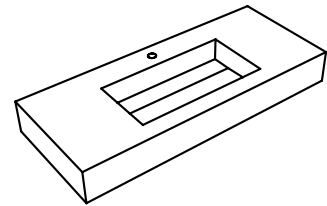

Possibilità di fissaggio a muro o in appoggio su apposita mensola. Ogni lavabo è fornito in apposita cassa Fao. Staffe di supporto su richiesta.
| Can be wall-mounted or mounted on a vanity shelf. Each washbasin comes in an ISPM 15 certified crate. Support brackets are available upon request. | Possibilité de la fixer au mur ou de la poser sur une tablette prévue à cet effet. Chaque vasque est emballée dans une caisse spéciale Fao. Supports de fixation sur demande. | Für die Montage an der Wand oder auf einer entsprechenden Auflageplatte. Jedes Waschbecken wird in einer entsprechenden Fao-Kiste geliefert. Halterungen auf Anfrage.

Clear T

Lavabi
Washbasins

**DOPPIO LAVABO INTEGRATO
CON CANALINA D'ISPEZIONE E FORO
PER RUBINETTERIA**

BUILT-IN DOUBLE WASHBASIN
WITH A CHANNEL DRAIN
AND A TAP HOLE

DOUBLE VASQUE INTÉGRÉE
AVEC GOULOTTE D'INSPECTION ET
TROU POUR ROBINETTERIE

INTEGRIERTES DOPPELWASHBECKEN
MIT INSPEKTIONSRIINNE UND
ARMATURENBOHRUNG

Clear/double.180 T

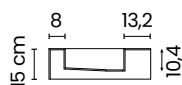
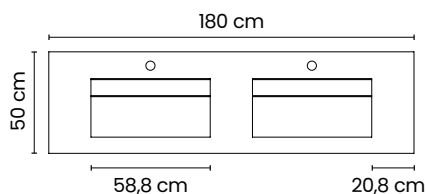
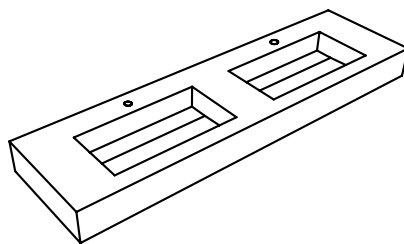

Possibilità di fissaggio a muro o in appoggio su apposita mensola. Ogni lavabo è fornito in apposita cassa Fao. Staffe di supporto su richiesta.
| Can be wall-mounted or mounted on a vanity shelf. Each washbasin comes in an ISPM 15 certified crate. Support brackets are available upon request. | Possibilité de la fixer au mur ou de la poser sur une tablette prévue à cet effet. Chaque vasque est emballée dans une caisse spéciale Fao. Supports de fixation sur demande. | Für die Montage an der Wand oder auf einer entsprechenden Auflageplatte. Jedes Waschbecken wird in einer entsprechenden Fao-Kiste geliefert. Halterungen auf Anfrage.

Limpid

Lavabi
Washbasins

LAVABO IN APPOGGIO
COUNTERTOP WASHBASIN
VASQUE D'APPUI
AUFSATZWASCHBECKEN

Limpid.50

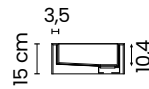
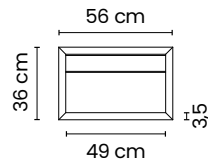
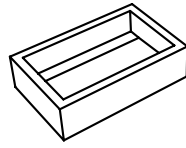

Limpid.90

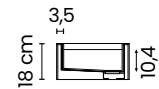
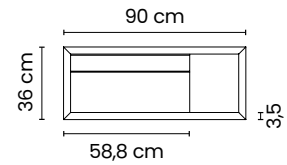
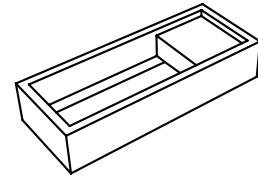

Limpid.120

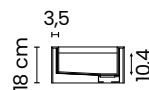
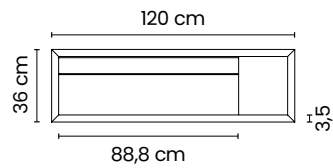
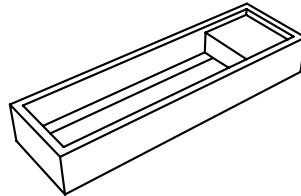

Lavabi in appoggio su piano. Ogni lavabo è fornito in apposita cassa Fao. | Countertop washbasin. Each washbasin comes in an ISPM 15 certified crate. | Vasque d'appui sur plan. Chaque vasque est emballée dans une caisse spéciale Fao. | Waschbecken als Auflagenaufsatz. Jedes Waschbecken wird in einer separaten Fao-Kiste geliefert.

Fluid

Lavabi
Washbasins

**LAVABO FREESTANDING
CON CANALINA D'ISPEZIONE**
FREESTANDING WASHBASIN
WITH A CHANNEL DRAIN
VASQUE AUTOPORTANTE
AVEC GOULOTTE D'INSPECTION
FREISTEHENDES WASCHBECKEN
MIT INSPEKTIONSRRINNE

Fluid.50_6 mm

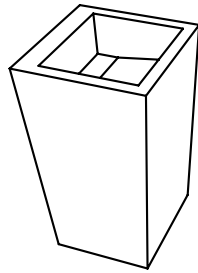

Fluid.50_9 mm

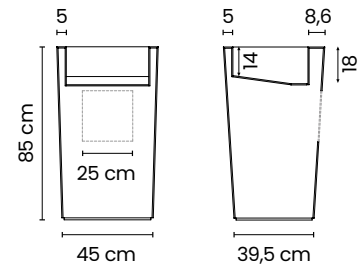
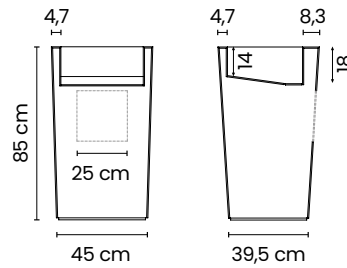
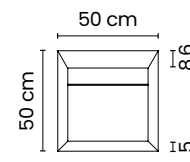
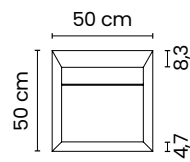
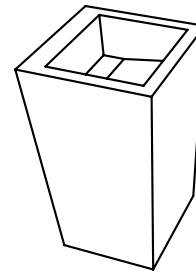

Ogni lavabo è provvisto di canalina di ispezione cromata ABS cod. CRIWA334S51 e imballo in apposita cassa Fao. | Each washbasin has a chrome-plated ABS channel drain (code CRIWA334S51) and comes in an ISPM 15 certified crate. | Chaque vasque est équipée d'une goulotte d'inspection chromée ABS code CRIWA334S51 et emballée dans une caisse spéciale Fao. | Jedes Waschbecken ist mit einer verchromten ABS-Inspektionsrinne (Code CRIWA334S51) versehen und in einer entsprechenden Fao-Kiste verpackt.

Cool

Mensole
Shelves

PIANO PORTA OGGETTI
BATHROOM SHELF
PLAN PORTE-OBJETS
ABLAGEPLATTE

Cool.60/75/90

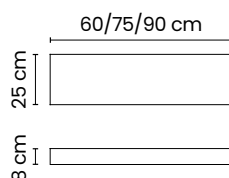
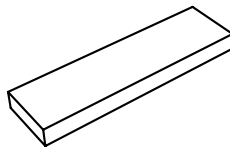

Ogni piano è provvisto di staffe di supporto per il fissaggio a muro e imballo in apposita cassa Fao. | Each shelf is provided with mounting brackets and comes in an ISPM 15 certified crate. | Chaque plan est équipé de supports pour fixation murale et emballé dans une caisse spéciale Fao. | Jede Ablage wird mit Halterungen für die Wandmontage geliefert und ist in einer entsprechenden Fao-Kiste verpackt.

Pure

Mensole
Shelves

Pure.90/120/180

PIANO LAVABO

VANITY TOP

PLAN VASQUE

WASCHBECKEN-AUFLAGEPLATTE

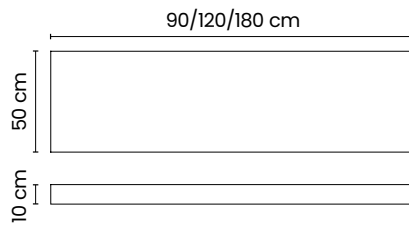
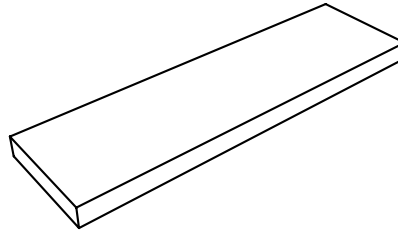

Ogni piano è provvisto di staffe di supporto per il fissaggio a muro e imballo in apposita cassa Fao. | Each shelf is provided with mounting brackets and comes in an ISPM 15 certified crate. | Chaque plan est équipé de supports pour fixation murale et emballé dans une caisse spéciale Fao. | Jede Auflage wird mit Halterungen für die Wandmontage geliefert und ist in einer entsprechenden Fao-Kiste verpackt.

Pure T

Mensole
Shelves

Pure.90 T/120 T

Pure.180 T

PIANO LAVABO

CON FORO DI SCARICO

VANITY TOP

WITH A DRAIN HOLE

PLAN VASQUE

AVEC TROU D'ÉVACUATION

WASCHBECKEN-AUFLAGEPLATTE

MIT BOHRUNG FÜR DEN ABFLUSS

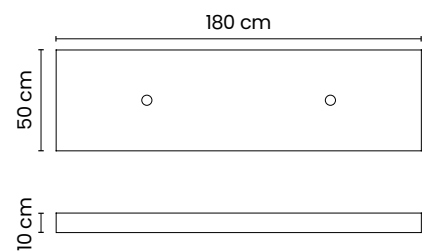
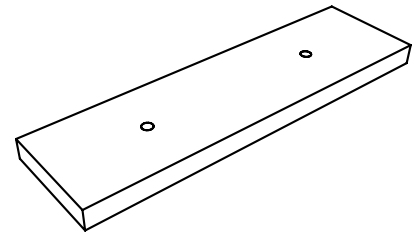
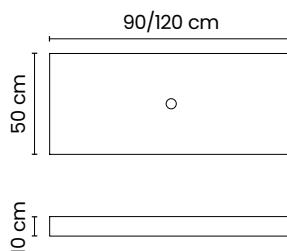
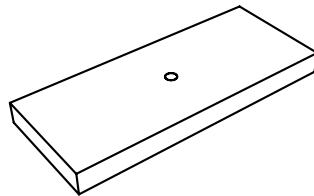

Piano con foro su richiesta per lo scarico o per rubinetteria, da definire al momento dell'ordine. Ogni piano è provvisto di staffe di supporto per il fissaggio a muro e imballo in apposita cassa Fao. | The drain or tap hole is available upon request and must be specified in the order. Each shelf is provided with mounting brackets and comes in an ISPM 15 certified crate. | Plan avec trou sur demande pour évacuation ou robinetterie, à définir lors de la commande. Chaque plan est équipé de supports pour fixation murale et emballé dans une caisse spéciale Fao. | Auflage mit Bohrung für Abfluss oder Armatur auf Anfrage erhältlich, bei der Bestellung festzulegen. Jede Auflage wird mit Halterungen für die Wandmontage geliefert und ist in einer entsprechenden Fao-Kiste verpackt.

Clean

Piatti doccia
Shower trays

**PIATTO DOCCIA RIALZATO
CON CANALINA LATERALE**

RAISED SHOWER TRAY
WITH SIDE CHANNEL DRAIN

RECEVEUR DE DOUCHE SURÉLEVÉ
AVEC GOULOTTE LATÉRALE

ERHÖHTE DUSCHTASSE
MIT SEITLICHER RINNE

Clean.80

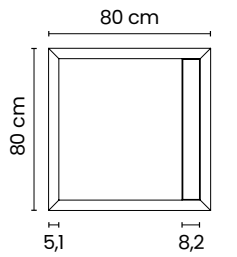
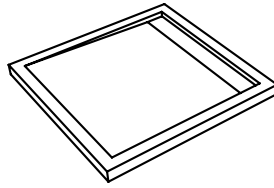

Clean.90

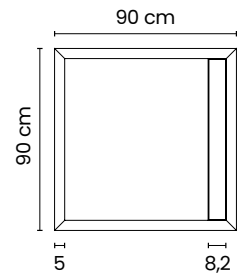
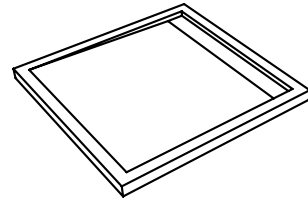

Clean.80x120

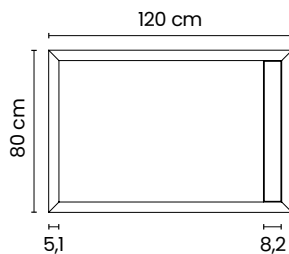
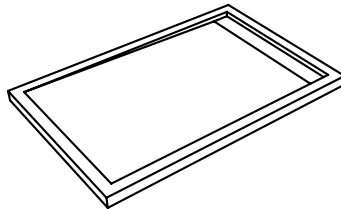

Clean.90x120

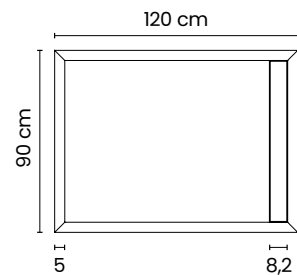
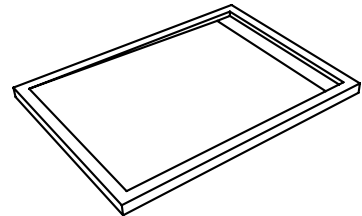

Piatto doccia rialzato o da incassare a filo pavimento. In fase di installazione è necessario controllare l'opportuna altezza del massetto. Ogni piatto doccia è provvisto di scarico Inox SILFRA AD 200 e imballo in apposita cassa Fao. | Raised or flush-mounted shower tray. Ensure an adequate screed height during installation. Each shower tray has a stainless steel drain and comes in an ISPM 15 certified crate. | Receveur de douche surélevé ou à encastrer au ras du sol. Lors de l'installation, il est nécessaire de contrôler la hauteur requise pour la chape. Chaque receveur de douche est équipé d'une évacuation Inox SILFRA AD 200 et emballé dans une caisse spéciale Fao. | Erhöhte oder bodenbündig eingelassene Duschtasse. Die entsprechende Höhe des Estrichs muss bei der Installation überprüft werden. Jede Duschtasse ist mit einem Ablauf aus Edelstahl vom Typ SILFRA AD 200 ausgestattet und in einer entsprechenden Fao-Kiste verpackt.

Fresh

Piatti doccia
Shower trays

**PIATTO DOCCIA TERMOFORMATO
IN GRES PORCELLANATO**

THERMOFORMED PORCELAIN
STONEWARE SHOWER TRAY

RECEVEUR DE DOUCHE THERMOFORMÉ
EN GRÈS CÉRAME

THERMOGEOFORMTE DUSCHTASSE
AUS FEINSTEINZEUG

Fresh.80

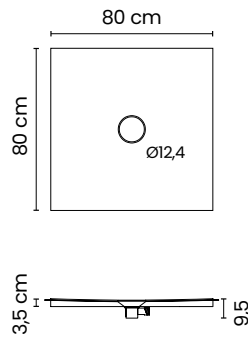
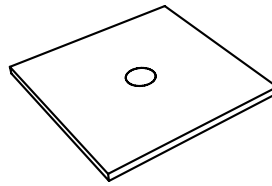

Fresh.90

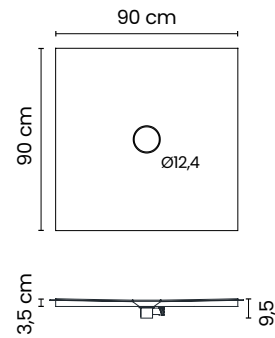
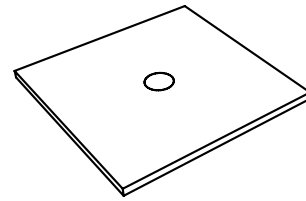

Fresh.80x120

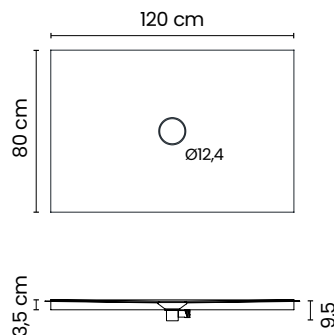
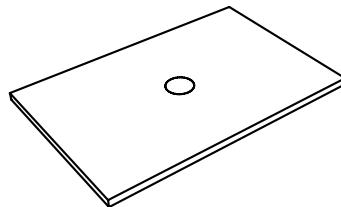

Fresh.90x120

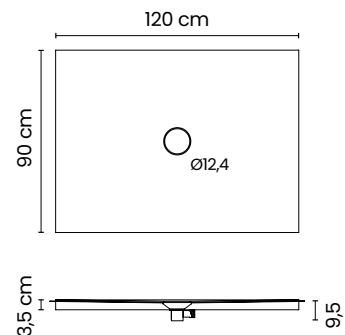
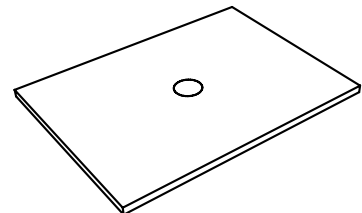

Piatto doccia da incassare a filo pavimento. In fase di installazione è necessario controllare l'opportuna altezza del massetto. Ogni piatto doccia è fornito di scarico Inox SILFRA AD 200 e imballo in apposita cassa Fao. | Flush-mounted shower tray. Ensure an adequate screed height during installation. Each shower tray has a stainless steel drain and comes in an ISPM 15 certified crate. | Receveur de douche à encastrer au ras du sol. Lors de l'installation, il est nécessaire de contrôler la hauteur requise pour la chape. Chaque receveur de douche est équipé d'une évacuation Inox SILFRA AD 200 et emballé dans une caisse spéciale Fao. | Bodenbündig eingelassene Duschtasse. Die entsprechende Höhe des Estrichs muss bei der Installation überprüft werden. Jede Duschtasse ist mit einem Ablauf aus Edelstahl vom Typ SILFRA AD 200 ausgestattet und in einer entsprechenden Fao-Kiste verpackt.

Strutture interne Internal parts

IT Per l'assemblaggio dei componenti Aquatio viene utilizzato un collante a base di mastice bicomponente epossidico. Nelle strutture interne dei prodotti sono presenti i seguenti materiali:

Lavabi La struttura interna dei lavabi è composta da una vaschetta in acciaio, da pannelli rigidi in polistirene estruso o realizzati con materiali idrofughi, assemblati con un silicone strutturale. Tutti i lati sono rivestiti da uno strato indurente e da un TNT che consente l'ancoraggio del collante. I lavabi sono dotati di piletta di scarico.

Mensole La struttura delle mensole è composta da pannelli rigidi in polistirene estruso o realizzati con materiali idrofughi assemblati con un silicone strutturale. Tutti i lati sono rivestiti da uno strato indurente e da un TNT che consente l'ancoraggio del collante.

Piatti doccia La struttura interna dei piatti doccia è costituita da pannelli in polistirene espanso, rivestiti con resina rasante e telo impermeabilizzante realizzato con tessuto in polipropilene stabilizzato con argilla espansa, assemblati con collante. I piatti doccia hanno una pendenza del 2% come da normativa e sono dotati di porta piletta e piletta sifonata per lo scarico ribassate, ideali come soluzione specifica anche in caso di fondo di posa limitato.

EN Aquatio components are assembled using a two-component epoxy adhesive. The internal parts of the products are made with the following materials:

Washbasins

The inside of the washbasins consists of a steel tray and rigid panels made of extruded polystyrene or water-repellent materials assembled with structural silicone. All sides are coated with a hardening layer and a non-woven fabric that allows the adhesive to adhere. The washbasins are equipped with a drain plug.

Shelves

The shelves are made with rigid panels made of extruded polystyrene or water-repellent materials assembled with structural silicone. All sides are coated with a hardening layer and a non-woven fabric that allows the adhesive to adhere.

Shower trays

The inside of the shower trays is made of polystyrene foam coated with smoothing resin and a waterproofing sheet made of polypropylene fabric stabilised with expanded clay assembled with adhesive. The shower trays have a 2% slope compliant with the relevant regulations. In addition, they are equipped with low-profile drain plugs and siphons, ideal in cases of limited installation depth.

FR Pour l'assemblage des composants Aquatio, un liant à base de mastic époxy à deux composants est utilisé. Voici les matériaux présents dans les structures internes des produits :

Vasques

La structure interne des vasques est composée d'un bac en acier, de panneaux rigides en polystyrène extrudé ou en matériaux hydrofuges, assemblés avec du silicone structurel. Toutes les faces sont recouvertes d'une couche durcissante et d'un tissu non tissé qui permet au liant d'adhérer. Les vasques sont équipées d'une bonde.

Tablettes

La structure des tablettes est composée de panneaux rigides en polystyrène extrudé ou en matériaux hydrofuges, assemblés avec du silicone structurel. Toutes les faces sont recouvertes d'une couche durcissante et d'un tissu non tissé qui permet au liant d'adhérer.

Receveurs de douche

La structure interne des receveurs de douche est constituée de panneaux en polystyrène expansé, enduits de résine d'enrobage et d'une feuille d'étanchéité en tissu de polypropylène stabilisé avec de l'argile expansée, assemblés avec un liant. Les receveurs de douche présentent une pente de 2 % conformément aux normes en vigueur et sont équipés d'un support de bonde et d'une bonde siphonnée surbaissés pour l'écoulement, parfaitement adaptés comme solution spécifique, y compris en cas d'espace d'installation limité.

DE Für die Montage der einzelnen Komponenten von Aquatio wird ein Zweikomponenten-Epoxidklebstoff verwendet. Folgende Materialien sind in den inneren Strukturen der Produkte enthalten:

Waschbecken

Die innere Struktur der Waschbecken besteht aus einem Stahlbecken, starren Platten aus extrudiertem Polystyrol oder wasserabweisenden Materialien, die mit Struktursilikon zusammengefügt werden. Alle Seiten sind mit einer härtenden Schicht und einem Vliesstoff beschichtet, der die Haftung des Klebers ermöglicht. Die Waschbecken sind mit einem Abfluss versehen.

Ablagen

Die Struktur der Ablagen besteht aus starren Platten aus extrudiertem Polystyrol oder wasserfesten Materialien, die mit Struktursilikon zusammengefügt werden. Alle Seiten sind mit einer härtenden Schicht und einem Vliesstoff beschichtet, der die Haftung des Klebers ermöglicht.

Duschtassen

Die innere Struktur der Duschtassen besteht aus expandierten Polystyrolplatten, die mit einem Abdeckharz und einer Abdichtungsfolie aus mit Blähton stabilisiertem Polypropylengewebe beschichtet und mit Klebstoff zusammengefügt sind. Die Duschtassen haben ein vorschrittsmäßiges Gefälle von 2 % und sind mit einer niedrigen Ablaufhalterung und einem Siphonablauf ausgestattet, der sich auch bei begrenztem Installationsraum als spezifische Lösung anbietet.

Personalizzazioni Tailor-made projects

IT Gli articoli della linea Aquatio possono essere realizzati utilizzando l'intera gamma di grandi lastre in gres porcellanato di Casalgrande Padana. È possibile modificare le dimensioni dei diversi modelli o realizzarli su misura, previa valutazione delle richieste e del progetto complessivo. La palette colori presentata (p.34-35) è specifica per i modelli della linea Aquatio. Su richiesta è possibile realizzare complementi d'arredo con altri colori e finiture. Per una migliore visione di cromie e texture, vi invitiamo a consultare il sito www.casalgrandepadana.com o i singoli cataloghi di collezione.

EN Aquatio items can be made with any of Casalgrande Padana's large-format porcelain stoneware tile collections. You can even change the dimensions or tailor them to the project's needs. The colour palette (see pages 34 and 35) is specific for models from the Aquatio range. Other colours and finishes are available upon request. We recommend visiting our website (www.casalgrandepadana.com) or viewing each collection's dedicated catalogue for a better idea of colours and textures.

FR Les articles de la ligne Aquatio peuvent être réalisés en utilisant l'ensemble de la gamme des grandes dalles en grès cérame de Casalgrande Padana. Il est possible de modifier les dimensions des différents modèles ou de les réaliser sur mesure, après évaluation des exigences et du projet dans son ensemble. La palette de couleurs présentée (pages 34-35) est spécifique aux modèles de la ligne Aquatio. Sur demande, il est possible de réaliser des compléments d'ameublement avec d'autres couleurs et finitions. Pour un meilleur aperçu des couleurs et des textures, veuillez consulter le site www.casalgrandepadana.com ou les catalogues des différentes collections.

DE Die Artikel der Produktlinie Aquatio können aus dem gesamten Sortiment der großen Feinsteinzeugplatten von Casalgrande Padana hergestellt werden. Es ist möglich, die Abmessungen der verschiedenen Modelle vorbehaltlich einer Überprüfung der Anforderungen und des Gesamtprojekts anzupassen oder sie nach Maß anzufertigen. Die vorgestellte Farbpalette (S.34-35) ist spezifisch für die Modelle der Produktreihe Aquatio. Andere Farben und Oberflächenausführungen sind auf Anfrage erhältlich. Eine bessere Übersicht über Farbgebungen und Texturen finden Sie unter www.casalgrandepadana.com oder in den jeweiligen Kollektionskatalogen.



WALL: Pietre di Sardegna_Porto Rotondo Naturale 120x278 cm
FLOOR: Pietre di Sardegna_Porto Rotondo Naturale 60x120 cm
AQUATIO: Limpid.120_Pietre di Sardegna_Porto Rotondo Naturale

I vantaggi della ceramica

The advantages of porcelain stoneware



SOSTENIBILE SUSTAINABLE

Completamente riciclabile. Non contiene plastica.
Fully recyclable. Does not contain plastic.



ECOLOGICA ENVIRONMENTALLY FRIENDLY

Rispetta ambiente e salute.
Conforme alle normative europee.
Helps protect the environment and human health. Meets all applicable European standards.



IGIENICA HYGIENIC

Inodore, non trattiene sporco e batteri. Facile da pulire.
Odourless, does not retain dirt and bacteria. Easy to clean.



DUREVOLE LONG-LASTING

Resistente a sollecitazioni esterne e abrasioni.
Withstands abrasion and stress.



IGNIFUGA FIRE-RESISTANT

Non brucia. Non rilascia sostanze nocive
Does not burn. Does not release harmful substances.



STABILE STABLE

Colori inalterabili nel tempo.
Non si deforma. Colours don't fade over time. Does not warp.



INGELIVA FROST-RESISTANT

Resiste al gelo e agli sbalzi di temperatura.
Withstands frost and temperature fluctuations.



INASSORBENTE NON-ABSORBENT

Non assorbe acqua.
Does not absorb water.



RESISTENTE STURDY

Inattaccabile da agenti chimici aggressivi.
Resists aggressive chemicals.

bios
antibacterial[®]



WATCH THE VIDEO
English

Superfici sostenibili Sustainable surfaces

Produrre materiali ceramici evoluti ed ecologici in un corretto equilibrio tra rispetto delle risorse naturali, protezione dell'ambiente, progresso tecnologico, crescita economica e responsabilità sociale sono caratteri profondamente radicati nel DNA di Casalgrande Padana. Priva di smalti e costituita esclusivamente da materie prime naturali la ceramica è ottenuta mediante un processo produttivo a ciclo chiuso, dove sofisticate apparecchiature antinquinamento consentono il riciclo e il recupero completo di tutte le componenti, con emissioni e dispersioni sostanzialmente nulle. Resistente, duratura e affidabile, la ceramica è una scelta progettuale decisamente orientata ai principi della sostenibilità.

The production of advanced, eco-friendly ceramic materials that strike just the right balance between respect for natural resources, environmental protection, technological progress, economic growth and social responsibility is profoundly rooted in Casalgrande Padana's DNA. Free from glazes and made exclusively from natural raw materials, the ceramic tiles are obtained using a closed-loop production process, in which elaborate anti-pollution equipment allows for the recycling and complete recovery of all the components, with substantially zero emissions and dispersion. Resistant, long-lasting and reliable, ceramic material is a decidedly eco-sustainable project design option.

Produire des matériaux céramiques évolués et écologiques dans un équilibre parfait entre respect des ressources naturelles, protection de l'environnement, progrès technologique, croissance économique et responsabilité sociale sont des valeurs profondément enracinées dans la philosophie de Casalgrande Padana. Dépouvue d'émaux et constituée exclusivement de matières premières naturelles, la céramique est obtenue à travers un processus de production en circuit fermé, où des équipements sophistiqués antipollution permettent le recyclage et la récupération complète de tous les composants, avec des émissions et des dispersions pratiquement nulles. Résistante, solide et fiable, la céramique est un choix conceptuel résolument orienté vers les principes de durabilité.

Fortschrittliche und ökologische Keramikmaterialien in der richtigen Balance zwischen Wahrung natürlicher Ressourcen, Umweltschutz, technischer Entwicklung, wirtschaftlichem Wachstum und sozialer Verantwortung herzustellen, ist eine Eigenschaft, die zutiefst in der DNS von Casalgrande Padana verankert ist. Ohne Lacke und ausschließlich aus natürlichen Rohstoffen gefertigt, wird Keramik in einem Herstellungsprozess mit geschlossenem Kreislauf gewonnen, in dem hochentwickelte Anlagen zur Vermeidung von Umweltverschmutzung das vollständige Recycling und die Rückgewinnung aller Komponenten ohne substanziale Emissionen und Dispersionen ermöglichen. Aufgrund ihrer Widerstandsfähigkeit, Langlebigkeit und Zuverlässigkeit ist Keramik eine Gestaltungswahl, die sich entschieden an den Prinzipien der Nachhaltigkeit orientiert.

 20.300 t

MATERIE PRIME RECUPERATE RECOVERED RAW MATERIALS

Utilizzo di scarti calcolati sul volume di produzione 2019.
Use of scrap calculated on the 2019 production volume.

 100%

IMBALLI ECOCOMPATIBILI ECO-COMPATIBLE PACKAGING

Impiego di Pallet Fao e imballi realizzati con materiali riciclati.
We use FAO pallets and packaging made with recycled materials.

 100%

RIDUZIONE DELL'IMPATTO IDRICO WATER IMPACT REDUCTION

Recupero delle acque reflue nel processo produttivo.
Wastewater recovery during the production process.

 77%

ENERGIA AUTOPRODOTTA SELF-PRODUCED ENERGY

Generata da impianti fotovoltaici e di cogenerazione.
Thanks to our cogeneration and photovoltaic systems.



Sistema di GESTIONE SICUREZZA certificato UNI ISO 45001:2018 CERTIFIED SAFETY MANAGEMENT SYSTEM UNI ISO 45001:2018

Produzione e commercializzazione di pavimenti e rivestimenti in ceramica.
Production and marketing of ceramic floor and wall tiles.

 99,5%

RIFIUTI RECUPERATI WASTE RECOVERED

Inviati alla raccolta differenziata.
Thanks to separate waste collection.



Casalgrande Padana ha adottato un sistema di gestione ambientale conforme al Regolamento EMAS allo scopo di attuare il miglioramento continuo delle proprie prestazioni ambientali pubblicando una dichiarazione ambientale convalidata dall'ente certificatore.

Casalgrande Padana has adopted an environmental management system that complies with the EMAS regulation to continuously improve our environmental performance. We have also published the environmental statement validated by the certification body.

Manutenzione e pulizia

Cleaning and maintenance

IT È importante sottolineare come la reazione antibatterica, per l'eliminazione dei germi, avvenga grazie al contatto degli agenti contaminanti con il principio attivo presente sulla superficie delle lastre ceramiche. È quindi fondamentale fare in modo che su questa superficie non si formino pellicole o film di alcun tipo, perché ne verrebbe inibita l'attività. Per consentire l'innovativo trattamento Bios Antibacterial® di esprimere al meglio tutte le sue potenzialità, è assolutamente da evitare l'uso di prodotti per la pulizia che contengano cere o protezioni di qualsiasi tipo. La manutenzione di Bios Antibacterial® non richiede particolari cure. Basta rispettare le seguenti norme:

Pulizia ordinaria: è sufficiente lavare il manufatto con acqua e aggiunta di normali prodotti detergenti per superfici ceramiche. Cere o prodotti analoghi di protezione NON devono mai essere usati, perché bloccano la reazione antibatterica della superficie. Bios Antibacterial® non trattiene macchie o aloni di qualsiasi genere. In presenza di eventuali macchie persistenti e difficili da togliere, si può comunque fare ricorso all'impiego appropriato di detergenti più forti e concentrati per ricondurre le superfici ceramiche all'aspetto originario. È opportuno segnalare che Bios Antibacterial® è resistente agli acidi, eccezione fatta per l'acido fluoridrico che attacca tutti i prodotti ceramici. Non utilizzare strumenti di pulizia abrasivi.

EN The tiles' antibacterial activity occurs when the contaminants come into contact with the active agent on the surface. Therefore, preventing films or layers that inhibit this activity is crucial. Do not use cleaning products containing waxes or any protective substance, as they would prevent the Bios Antibacterial® treatment from expressing its full potential. Tiles treated with Bios Antibacterial® do not require particular maintenance. Simply follow these instructions:

Everyday cleaning: wash the tiles with water and ordinary detergents suitable for ceramic surfaces. NEVER use waxes and similar protective products as they would hinder the tile treatment's antibacterial effect. Bios Antibacterial® tiles do not retain stains or halos of any kind. However, in the event of tough stains, you can use stronger concentrated detergents to bring the tiles back to their pristine appearance. Please note that Bios Antibacterial® resists all chemicals except hydrofluoric acid, which attacks all ceramic products. Do not use abrasive cleaning tools and products.

FR Il est important de souligner comment la réaction antibactérienne visant à éliminer les germes se produit grâce au contact des agents contaminants avec le principe actif présent sur la surface des dalles céramiques. Il est donc fondamental de veiller à ce qu'aucune sorte de pellicule ou de film ne se forme sur cette surface ; dans le cas contraire, l'activité serait inhibée. Pour permettre au traitement innovant Bios Antibacterial® d'exprimer au mieux toutes ses potentialités, il est absolument interdit d'utiliser des produits de nettoyage contenant des cires ou des protections, quel qu'en soit leur type. Pour entretenir Bios Antibacterial®, aucun soin particulier n'est nécessaire. Il suffit de respecter les normes suivantes :

Nettoyage ordinaire : il suffit de laver le produit avec de l'eau en y ajoutant des détergents courants destinés aux surfaces céramiques. Il NE faut JAMAIS utiliser de cires ou de produits de protection similaires car ils inhibent la réaction antibactérienne de la surface. Bios Antibacterial® ne retient aucun type de tache ou d'auréole. En présence d'éventuelles taches persistantes et difficiles à retirer, il est toutefois possible d'avoir recours à l'utilisation appropriée de détergents plus forts et concentrés pour redonner aux surfaces céramiques leur aspect d'origine. Il convient de signaler que Bios Antibacterial® résiste aux acides, à l'exception de l'acide fluorhydrique qui attaque tous les produits céramiques. Ne pas utiliser d'outils de nettoyage abrasifs.

DE Es ist wichtig zu betonen, dass die antibakterielle Wirkung zur Beseitigung von Keimen durch den Kontakt der kontaminierenden Erreger mit dem auf der Oberfläche der Keramikplatten vorhandenen Wirkstoff entsteht. Es muss deshalb unbedingt darauf geachtet werden, dass sich auf dieser Oberfläche kein wie auch immer gearteter Film oder Belag bildet, da dieser die Wirkung hemmen würde. Damit die innovative Behandlung Bios Antibacterial® ihr volles Potenzial entfalten kann, sollte die Verwendung von Reinigungsprodukten, die Wachse oder Schutzmittel jeglicher Art enthalten, unbedingt vermieden werden. Die Pflege von Bios Antibacterial® erfordert keine besondere Vorgehensweise. Es müssen nur die folgenden Regeln beachtet werden:

Gewöhnliche Reinigung: Der Bodenbelag wird einfach mit Wasser und der Zugabe von normalen Reinigungsmitteln für keramische Oberflächen gereinigt. Wachse oder ähnliche Schutzprodukte sollten NIEMALS verwendet werden, da sie die antibakterielle Wirkung der Oberfläche blockieren. Bios Antibacterial® hinterlässt keine Flecken oder Lichthöfe jeglicher Art. Bei hartnäckigen Flecken, die sich nur schwer entfernen lassen, können stärkere, konzentriertere Reinigungsmittel verwendet werden, um das ursprüngliche Aussehen der Fliesen wiederherzustellen. Es sei darauf hingewiesen, dass Bios Antibacterial® beständig gegen Säuren ist, mit Ausnahme von Flusssäure, die alle keramischen Produkte angreift. Keine scheuernden Reinigungswerkzeuge verwenden.



© Copyright Casalgrande Padana

Casalgrande Padana si riserva la facoltà di apportare in qualsiasi momento e senza preavviso modifiche estetiche ai propri prodotti che si rendessero necessarie in seguito all'evoluzione tecnologica e all'ottimizzazione produttiva.

I colori e l'estetica dei prodotti sono quanto più possibile vicini a quelli reali nei limiti dei processi di stampa.

Casalgrande Padana reserves the right, at any time and without prior notice to make any aesthetic changes to its products that may be required as a result of technological developments and product optimisation.

The colour and appearance of the products as shown are as close as possible to the real thing, inside the limitations of the printing process.

Casalgrande Padana se réserve le droit d'apporter à tout moment et sans préavis des modifications esthétiques à ses produits, qui se rendraient nécessaire à la suite de l'évolution technologique et de l'optimisation de la production. Les couleurs et l'apparence des produits sont aussi fidèles à la réalité que possible, dans les limites des processus d'impression.

Casalgrande Padana behält sich das Recht vor, jederzeit bei Bedarf und ohne Vorankündigung infolge von technischer Entwicklung und Erforschung der Produktoptimierung optische Änderungen an den eigenen Produkten vorzunehmen. Die Farben und das Aussehen der Produkte entsprechen den tatsächlichen Produkten, soweit dies im Rahmen der Druckprozesse möglich ist.

Questo catalogo è stampato su carta certificata FSC®.
This catalog is printed on FSC® certified paper.





CASALGRANDE
PADANA
THE GREEN WAY TO PAVE

Via Statale 467, n°73 - 42013 Casalgrande (RE) - Italia
Tel +39 0522 9901 - Fax +39 0522 996121
info@casalgrandepadana.it - www.casalgrandepadana.com

